

# Chip Coils



## High Frequency Winding Type LQW15A/LQW18A Series

### LQW15A\_00 Series

The LQW15A series consists of air core chip coil using a miniature alumina core.  
The tight inductance tolerance (+/-0.2nH, +/-3%) is available due to Murata's original winding technology.  
The LQW15A series has high Q value in high frequency range and high self resonant frequency. It is suitable for high frequency circuits which are used in telecommunication equipment.

#### ■ Features

1. Horizontal winding structure enables tight inductance tolerance (+/-0.2nH, +/-3%)
2. The subminiature dimensions (1.0x0.5mm) allow high density mounting.
3. The high self resonant frequency realizes high Q value and stable inductance at high frequency.
4. Low DC resistance design is ideal for low loss, high output and low power consumption.
5. Resin-coated surface enables excellent mounting.

#### ■ Applications

1. High frequency circuits of mobile phones such as PA, ANT, VCO, SAW, etc.
2. Mobile phones such as GSM, CDMA, PDC, etc.
3. "Bluetooth"
4. W-LAN
5. High frequency circuits in general

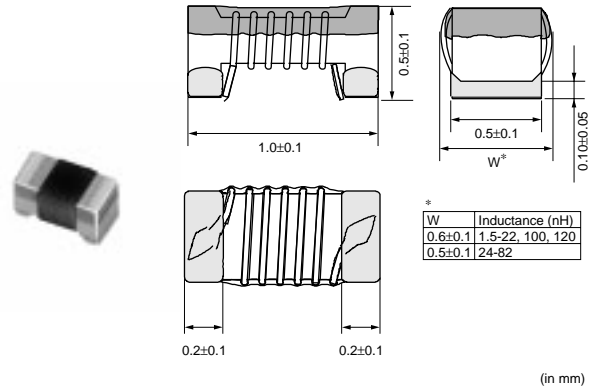

Part Number	Inductance (nH)	Test Frequency (MHz)	Rated Current (mA)	DC Resistance (ohm)	Q (min.)	Test Frequency (MHz)	Self Resonance Frequency (min.) (GHz)	EIA
LQW15AN1N5C00	1.5 ±0.2nH	100	1000	0.03 max.	10	250	18.0	0402
LQW15AN1N5D00	1.5 ±0.5nH	100	1000	0.03 max.	10	250	18.0	0402
LQW15AN2N4C00	2.4 ±0.2nH	100	850	0.05 max.	20	250	15.0	0402
LQW15AN2N4D00	2.4 ±0.5nH	100	850	0.05 max.	20	250	15.0	0402
LQW15AN2N5C00	2.5 ±0.2nH	100	850	0.05 max.	20	250	15.0	0402
LQW15AN2N5D00	2.5 ±0.5nH	100	850	0.05 max.	20	250	15.0	0402
LQW15AN2N7C00	2.7 ±0.2nH	100	850	0.05 max.	20	250	15.0	0402
LQW15AN2N7D00	2.7 ±0.5nH	100	850	0.05 max.	20	250	15.0	0402
LQW15AN3N9C00	3.9 ±0.2nH	100	750	0.07 max.	25	250	10.0	0402
LQW15AN3N9D00	3.9 ±0.5nH	100	750	0.07 max.	25	250	10.0	0402
LQW15AN4N3C00	4.3 ±0.2nH	100	750	0.07 max.	25	250	10.0	0402
LQW15AN4N3D00	4.3 ±0.5nH	100	750	0.07 max.	25	250	10.0	0402
LQW15AN4N7C00	4.7 ±0.2nH	100	750	0.07 max.	25	250	8.0	0402
LQW15AN4N7D00	4.7 ±0.5nH	100	750	0.07 max.	25	250	8.0	0402
LQW15AN5N1C00	5.1 ±0.2nH	100	600	0.12 max.	25	250	8.0	0402
LQW15AN5N1D00	5.1 ±0.5nH	100	600	0.12 max.	25	250	8.0	0402
LQW15AN5N8C00	5.8 ±0.2nH	100	700	0.12 max.	25	250	8.0	0402
LQW15AN5N8D00	5.8 ±0.5nH	100	700	0.12 max.	25	250	8.0	0402
LQW15AN6N2C00	6.2 ±0.2nH	100	700	0.09 max.	25	250	8.0	0402
LQW15AN6N2D00	6.2 ±0.5nH	100	700	0.09 max.	25	250	8.0	0402

Continued on the following page.

Continued from the preceding page.

Part Number	Inductance (nH)	Test Frequency (MHz)	Rated Current (mA)	DC Resistance (ohm)	Q (min.)	Test Frequency (MHz)	Self Resonance Frequency (min.) (GHz)	EIA
LQW15AN6N8H00	6.8 ±3%	100	700	0.09 max.	25	250	6.0	0402
LQW15AN6N8J00	6.8 ±5%	100	700	0.09 max.	25	250	6.0	0402
LQW15AN7N5H00	7.5 ±3%	100	570	0.13 max.	25	250	6.0	0402
LQW15AN7N5J00	7.5 ±5%	100	570	0.13 max.	25	250	6.0	0402
LQW15AN8N2H00	8.2 ±3%	100	540	0.14 max.	25	250	5.5	0402
LQW15AN8N2J00	8.2 ±5%	100	540	0.14 max.	25	250	5.5	0402
LQW15AN8N7H00	8.7 ±3%	100	540	0.14 max.	25	250	5.5	0402
LQW15AN8N7J00	8.7 ±5%	100	540	0.14 max.	25	250	5.5	0402
LQW15AN9N1H00	9.1 ±3%	100	540	0.14 max.	25	250	5.5	0402
LQW15AN9N1J00	9.1 ±5%	100	540	0.14 max.	25	250	5.5	0402
LQW15AN10NH00	10 ±3%	100	500	0.17 max.	25	250	5.5	0402
LQW15AN10NJ00	10 ±5%	100	500	0.17 max.	25	250	5.5	0402
LQW15AN11NH00	11 ±3%	100	500	0.14 max.	30	250	5.5	0402
LQW15AN11NJ00	11 ±5%	100	500	0.14 max.	30	250	5.5	0402
LQW15AN12NH00	12 ±3%	100	500	0.14 max.	30	250	5.5	0402
LQW15AN12NJ00	12 ±5%	100	500	0.14 max.	30	250	5.5	0402
LQW15AN13NH00	13 ±3%	100	430	0.21 max.	25	250	5.0	0402
LQW15AN13NJ00	13 ±5%	100	430	0.21 max.	25	250	5.0	0402
LQW15AN15NH00	15 ±3%	100	460	0.16 max.	30	250	5.0	0402
LQW15AN15NJ00	15 ±5%	100	460	0.16 max.	30	250	5.0	0402
LQW15AN16NH00	16 ±3%	100	370	0.24 max.	25	250	4.5	0402
LQW15AN16NJ00	16 ±5%	100	370	0.24 max.	25	250	4.5	0402
LQW15AN18NH00	18 ±3%	100	370	0.27 max.	25	250	4.5	0402
LQW15AN18NJ00	18 ±5%	100	370	0.27 max.	25	250	4.5	0402
LQW15AN19NH00	19 ±3%	100	370	0.27 max.	25	250	4.5	0402
LQW15AN19NJ00	19 ±5%	100	370	0.27 max.	25	250	4.5	0402
LQW15AN22NH00	22 ±3%	100	310	0.30 max.	25	250	4.0	0402
LQW15AN22NJ00	22 ±5%	100	310	0.30 max.	25	250	4.0	0402
LQW15AN24NH00	24 ±3%	100	280	0.52 max.	25	250	3.5	0402
LQW15AN24NJ00	24 ±5%	100	280	0.52 max.	25	250	3.5	0402
LQW15AN27NH00	27 ±3%	100	280	0.52 max.	25	250	3.5	0402
LQW15AN27NJ00	27 ±5%	100	280	0.52 max.	25	250	3.5	0402
LQW15AN30NH00	30 ±3%	100	270	0.58 max.	25	250	3.3	0402
LQW15AN30NJ00	30 ±5%	100	270	0.58 max.	25	250	3.3	0402
LQW15AN33NH00	33 ±3%	100	260	0.63 max.	25	250	3.2	0402
LQW15AN33NJ00	33 ±5%	100	260	0.63 max.	25	250	3.2	0402
LQW15AN36NH00	36 ±3%	100	260	0.63 max.	25	250	3.1	0402
LQW15AN36NJ00	36 ±5%	100	260	0.63 max.	25	250	3.1	0402
LQW15AN39NH00	39 ±3%	100	250	0.70 max.	25	250	3.0	0402
LQW15AN39NJ00	39 ±5%	100	250	0.70 max.	25	250	3.0	0402
LQW15AN47NH00	47 ±3%	100	210	1.08 max.	25	200	2.9	0402
LQW15AN47NJ00	47 ±5%	100	210	1.08 max.	25	200	2.9	0402
LQW15AN56NH00	56 ±3%	100	200	1.17 max.	25	200	2.8	0402
LQW15AN56NJ00	56 ±5%	100	200	1.17 max.	25	200	2.8	0402
LQW15AN68NJ00	68 ±5%	100	140	1.96 max.	20	200	2.5	0402
LQW15AN82NJ00	82 ±5%	100	130	2.24 max.	20	150	2.3	0402
LQW15ANR10J00	100 ±5%	100	120	2.52 max.	20	150	1.5	0402
LQW15ANR12J00	120 ±5%	100	110	2.66 max.	20	150	1.0	0402

Operating Temp. Range : -55°C to +125°C  
Please use reflow soldering.

■ Q-Frequency Characteristics

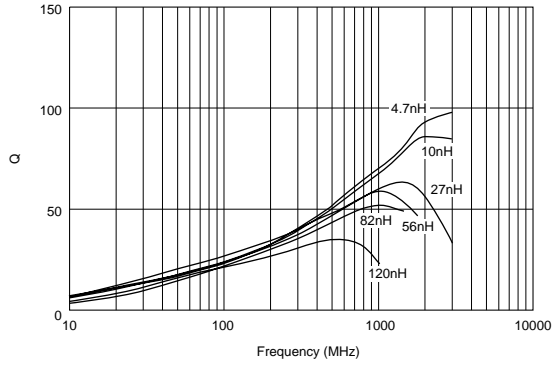

■ Inductance-Frequency Characteristics

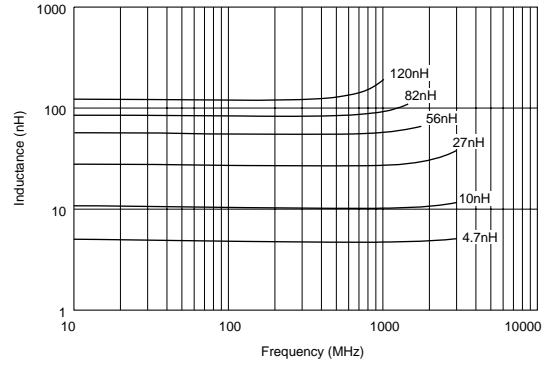

■ Reference Data

LQW15AN\_00

E4991A & 16197A

Part Number	Inductance (nH)	Q (Typ.)						
	Nominal	300MHz	800MHz	900MHz	1.5GHz	1.8GHz	2.0GHz	2.4GHz
LQW15AN1N5	1.5	30	55	60	65	90	100	115
LQW15AN2N4	2.4	40	65	67	80	98	108	120
LQW15AN2N5	2.5	40	65	67	88	90	100	110
LQW15AN2N7	2.7	40	67	73	85	100	105	120
LQW15AN3N9	3.9	40	61	64	84	90	95	110
LQW15AN4N3	4.3	40	65	68	90	95	100	105
LQW15AN4N7	4.7	40	65	67	85	88	92	95
LQW15AN5N1	5.1	35	60	65	78	85	90	95
LQW15AN5N8	5.8	40	63	67	85	88	92	105
LQW15AN6N2	6.2	40	63	65	80	90	95	105
LQW15AN6N8	6.8	45	70	72	90	96	100	103
LQW15AN7N5	7.5	38	58	63	75	88	90	92
LQW15AN8N2	8.2	40	62	67	80	90	95	102
LQW15AN8N7	8.7	40	60	62	80	85	90	92
LQW15AN9N1	9.1	40	62	68	85	90	92	95
LQW15AN10N	10	38	60	65	75	82	85	84
LQW15AN11N	11	40	65	70	90	105	110	120
LQW15AN12N	12	40	60	62	80	85	90	91
LQW15AN13N	13	40	60	62	70	72	71	67
LQW15AN15N	15	40	60	65	80	85	88	90
LQW15AN16N	16	40	60	63	80	90	100	110
LQW15AN18N	18	40	63	65	80	88	87	85
LQW15AN19N	19	40	63	65	90	105	110	130
LQW15AN22N	22	35	55	58	65	65	63	57
LQW15AN24N	24	35	50	50	48	42	-	-
LQW15AN27N	27	35	55	56	60	58	-	-
LQW15AN30N	30	35	55	58	65	68	-	-
LQW15AN33N	33	35	55	56	60	53	-	-
LQW15AN36N	36	35	52	52	48	42	-	-
LQW15AN39N	39	35	55	56	55	-	-	-
LQW15AN47N	47	38	55	58	65	-	-	-
LQW15AN56N	56	38	53	55	50	-	-	-
LQW15AN68N	68	35	49	52	-	-	-	-
LQW15AN82N	82	35	49	50	-	-	-	-
LQW15ANR10	100	30	43	43	-	-	-	-
LQW15ANR12	120	28	30	23	-	-	-	-

## LQW15A\_10 Series (High Q/Low DC Resistance Type)

### ■ Features

Lower DC resistance approximately by 50% than current type. Higher Q by 20%, larger rated current by 20%.

Inductance range: 1.3 to 5.6nH

Inductance tolerance: +/-0.2 or 0.5nH

Q (Typ.) : 83 to 122 (at 1GHz)

DC Resistance: 0.017 to 0.051 ohm

Rated Current: 800 to 1200mA

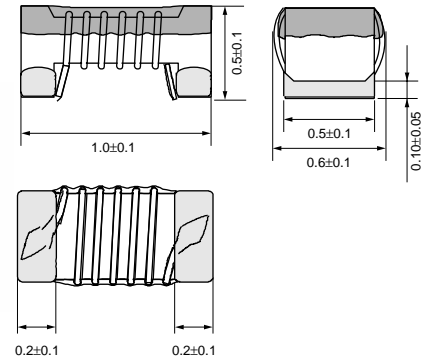

(in mm)

### ■ Applications

1. Cellular phone and Base station
2. W-CDMA, GSM, N-CDMA, PDC
3. Higher Q -- Matching circuit for antenna, SAW filter
4. Lower R<sub>dc</sub> -- Choke coil for IF, RF circuit like PA Equipment with high frequency circuits (Wireless LAN etc).

Part Number	Inductance (nH)	Test Frequency (MHz)	Rated Current (mA)	DC Resistance (ohm)	Q (min.)	Test Frequency (MHz)	Self Resonance Frequency (min.) (GHz)	EIA
LQW15AN1N3C10	1.3 ±0.2nH	100	1200	0.017 max.	20	250	16.0	0402
LQW15AN1N3D10	1.3 ±0.5nH	100	1200	0.017 max.	20	250	16.0	0402
LQW15AN2N2C10	2.2 ±0.2nH	100	1000	0.027 max.	25	250	14.0	0402
LQW15AN2N2D10	2.2 ±0.5nH	100	1000	0.027 max.	25	250	14.0	0402
LQW15AN2N4D10	2.4 ±0.5nH	100	1000	0.027 max.	25	250	14.0	0402
LQW15AN3N3D10	3.3 ±0.5nH	100	900	0.040 max.	30	250	12.0	0402
LQW15AN3N6C10	3.6 ±0.2nH	100	900	0.040 max.	30	250	9.5	0402
LQW15AN3N6D10	3.6 ±0.5nH	100	900	0.040 max.	30	250	9.5	0402
LQW15AN3N9D10	3.9 ±0.5nH	100	900	0.040 max.	30	250	7.0	0402
LQW15AN4N7D10	4.7 ±0.5nH	100	800	0.051 max.	30	250	8.0	0402
LQW15AN5N1C10	5.1 ±0.2nH	100	800	0.051 max.	30	250	8.0	0402
LQW15AN5N1D10	5.1 ±0.5nH	100	800	0.051 max.	30	250	8.0	0402
LQW15AN5N6C10	5.6 ±0.2nH	100	800	0.051 max.	30	250	8.0	0402
LQW15AN5N6D10	5.6 ±0.5nH	100	800	0.051 max.	30	250	8.0	0402

Operating Temp. Range : -55°C to +125°C

Please use reflow soldering.

### ■ Q-Frequency Characteristics

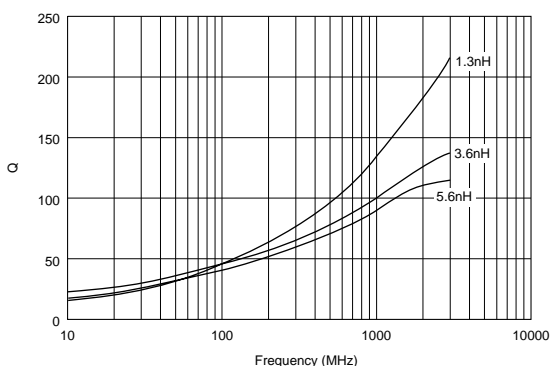

### ■ Inductance-Frequency Characteristics

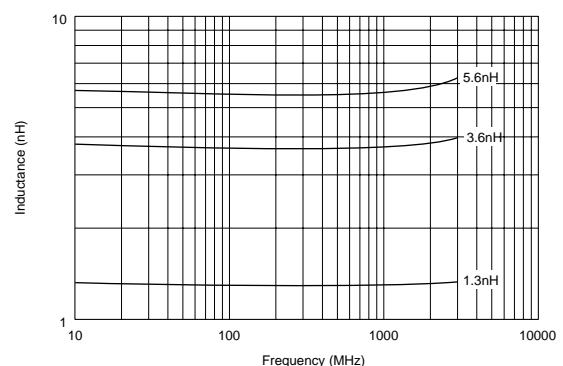

Continued on the following page. ↗

Continued from the preceding page.

**Reference Data**

**LQW15AN\_10**

E4991A & 16197A

Part Number	Inductance (nH)	Q (Typ.)						
		Nominal	800MHz	900MHz	1.0GHz	1.5GHz	1.8GHz	2.0GHz
LQW15AN1N3	1.3	90	95	100	130	145	160	180
LQW15AN2N2	2.2	85	90	95	115	130	140	160
LQW15AN2N4	2.4	80	85	90	110	130	140	160
LQW15AN3N3	3.3	80	85	90	110	120	128	140
LQW15AN3N6	3.6	73	75	85	100	110	115	130
LQW15AN3N9	3.9	75	80	83	95	110	115	120
LQW15AN4N7	4.7	75	80	85	100	113	120	132
LQW15AN5N1	5.1	75	80	85	100	110	115	128
LQW15AN5N6	5.6	70	75	78	95	100	105	110

**Features LQW18A\_00 (Standard type)**

1. Broad range of inductance (2.2nH to 470nH) with E24 step line up.
2. Horizontal winding structure enables tight inductance tolerance (+0.2nH, +-2%). Stable circuit operation is possible.
3. The subminiature dimensions (1.6x0.8mm) allow high density mounting.
4. The high self resonant frequency realizes high Q value and stable inductance at high frequency.
5. Low DC resistance design is ideal for low loss, high output and low power consumption.
6. Resin-coated surface enables excellent mounting.

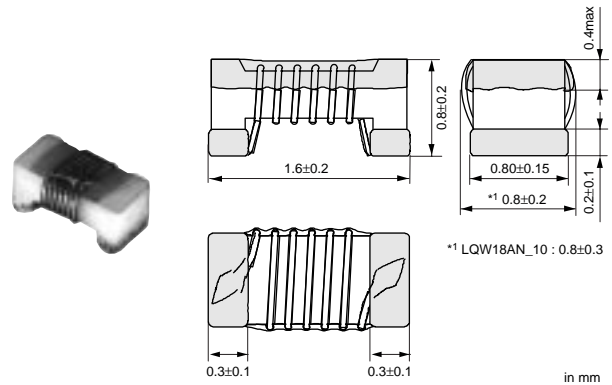

**Applications**

1. High frequency circuits of mobile phones such as PA, ANT, VCO, SAW, etc.
2. Mobile phones such as GSM, CDMA, PDC, etc.
3. "Bluetooth"
4. W-LAN
5. High frequency circuits in general

**Features LQW18A\_10 (High Q/Low DC Resistance type)**

Lower DC Resistance approximately by 50% than current type. Higher Q by 10%, higher rated current by 20%.

**Applications**

Cellular phone and Base station  
W-CDMA, GSM, N-CDMA, PDC  
Higher Q -- Matching circuit for antenna, SAW filter  
Lower Rdc -- Choke coil for IF, RF circuit like PA  
Equipment with high frequency circuits  
(Wireless LAN, etc.)

**LQW18A\_00 Series**

Part Number	Inductance (nH)	Test Frequency (MHz)	Rated Current (mA)	DC Resistance (ohm)	Q (min.)	Test Frequency (MHz)	Self Resonance Frequency (min.) (MHz)	EIA
LQW18AN2N2D00	2.2 ±0.5nH	100	700	0.049 max.	16	250	6000	0603
LQW18AN3N6C00	3.6 ±0.2nH	100	850	0.059 max.	25	250	6000	0603
LQW18AN3N6D00	3.6 ±0.5nH	100	850	0.059 max.	25	250	6000	0603
LQW18AN3N9C00	3.9 ±0.2nH	100	850	0.059 max.	35	250	6000	0603
LQW18AN3N9D00	3.9 ±0.5nH	100	850	0.059 max.	35	250	6000	0603
LQW18AN4N3C00	4.3 ±0.2nH	100	850	0.059 max.	35	250	6000	0603

Continued on the following page.

Continued from the preceding page.

Part Number	Inductance (nH)	Test Frequency (MHz)	Rated Current (mA)	DC Resistance (ohm)	Q (min.)	Test Frequency (MHz)	Self Resonance Frequency (min.) (MHz)	EIA
LQW18AN4N3D00	4.3 ±0.5nH	100	850	0.059 max.	35	250	6000	0603
LQW18AN4N7D00	4.7 ±0.5nH	100	850	0.059 max.	35	250	6000	0603
LQW18AN5N6C00	5.6 ±0.2nH	100	750	0.082 max.	35	250	6000	0603
LQW18AN5N6D00	5.6 ±0.5nH	100	750	0.082 max.	35	250	6000	0603
LQW18AN6N2C00	6.2 ±0.2nH	100	750	0.082 max.	35	250	6000	0603
LQW18AN6N2D00	6.2 ±0.5nH	100	750	0.082 max.	35	250	6000	0603
LQW18AN6N8C00	6.8 ±0.2nH	100	750	0.082 max.	35	250	6000	0603
LQW18AN6N8D00	6.8 ±0.5nH	100	750	0.082 max.	35	250	6000	0603
LQW18AN7N5D00	7.5 ±0.5nH	100	750	0.082 max.	35	250	6000	0603
LQW18AN8N2D00	8.2 ±0.5nH	100	650	0.11 max.	35	250	6000	0603
LQW18AN8N7D00	8.7 ±0.5nH	100	650	0.11 max.	35	250	6000	0603
LQW18AN9N1D00	9.1 ±0.5nH	100	650	0.11 max.	35	250	6000	0603
LQW18AN9N5D00	9.5 ±0.5nH	100	650	0.11 max.	35	250	6000	0603
LQW18AN10NG00	10 ±2%	100	650	0.11 max.	35	250	6000	0603
LQW18AN10NJ00	10 ±5%	100	650	0.11 max.	35	250	6000	0603
LQW18AN11NG00	11 ±2%	100	650	0.11 max.	35	250	6000	0603
LQW18AN11NJ00	11 ±5%	100	650	0.11 max.	35	250	6000	0603
LQW18AN12NG00	12 ±2%	100	600	0.13 max.	35	250	6000	0603
LQW18AN12NJ00	12 ±5%	100	600	0.13 max.	35	250	6000	0603
LQW18AN13NG00	13 ±2%	100	600	0.13 max.	35	250	6000	0603
LQW18AN13NJ00	13 ±5%	100	600	0.13 max.	35	250	6000	0603
LQW18AN15NG00	15 ±2%	100	600	0.13 max.	40	250	6000	0603
LQW18AN15NJ00	15 ±5%	100	600	0.13 max.	40	250	6000	0603
LQW18AN16NG00	16 ±2%	100	550	0.16 max.	40	250	5500	0603
LQW18AN16NJ00	16 ±5%	100	550	0.16 max.	40	250	5500	0603
LQW18AN18NG00	18 ±2%	100	550	0.16 max.	40	250	5500	0603
LQW18AN18NJ00	18 ±5%	100	550	0.16 max.	40	250	5500	0603
LQW18AN20NG00	20 ±2%	100	550	0.16 max.	40	250	4900	0603
LQW18AN20NJ00	20 ±5%	100	550	0.16 max.	40	250	4900	0603
LQW18AN22NG00	22 ±2%	100	500	0.17 max.	40	250	4600	0603
LQW18AN22NJ00	22 ±5%	100	500	0.17 max.	40	250	4600	0603
LQW18AN24NG00	24 ±2%	100	500	0.21 max.	40	250	3800	0603
LQW18AN24NJ00	24 ±5%	100	500	0.21 max.	40	250	3800	0603
LQW18AN27NG00	27 ±2%	100	440	0.21 max.	40	250	3700	0603
LQW18AN27NJ00	27 ±5%	100	440	0.21 max.	40	250	3700	0603
LQW18AN30NG00	30 ±2%	100	420	0.23 max.	40	250	3300	0603
LQW18AN30NJ00	30 ±5%	100	420	0.23 max.	40	250	3300	0603
LQW18AN33NG00	33 ±2%	100	420	0.23 max.	40	250	3200	0603
LQW18AN33NJ00	33 ±5%	100	420	0.23 max.	40	250	3200	0603
LQW18AN36NG00	36 ±2%	100	400	0.26 max.	40	250	2900	0603
LQW18AN36NJ00	36 ±5%	100	400	0.26 max.	40	250	2900	0603
LQW18AN39NG00	39 ±2%	100	400	0.26 max.	40	250	2800	0603
LQW18AN39NJ00	39 ±5%	100	400	0.26 max.	40	250	2800	0603
LQW18AN43NG00	43 ±2%	100	380	0.29 max.	40	200	2700	0603
LQW18AN43NJ00	43 ±5%	100	380	0.29 max.	40	200	2700	0603
LQW18AN47NG00	47 ±2%	100	380	0.29 max.	38	200	2600	0603
LQW18AN47NJ00	47 ±5%	100	380	0.29 max.	38	200	2600	0603
LQW18AN51NG00	51 ±2%	100	370	0.33 max.	38	200	2500	0603
LQW18AN51NJ00	51 ±5%	100	370	0.33 max.	38	200	2500	0603
LQW18AN56NG00	56 ±2%	100	360	0.35 max.	38	200	2400	0603
LQW18AN56NJ00	56 ±5%	100	360	0.35 max.	38	200	2400	0603
LQW18AN62NG00	62 ±2%	100	280	0.51 max.	38	200	2300	0603
LQW18AN62NJ00	62 ±5%	100	280	0.51 max.	38	200	2300	0603
LQW18AN68NG00	68 ±2%	100	340	0.38 max.	38	200	2200	0603
LQW18AN68NJ00	68 ±5%	100	340	0.38 max.	38	200	2200	0603
LQW18AN72NG00	72 ±2%	100	270	0.56 max.	34	150	2100	0603
LQW18AN72NJ00	72 ±5%	100	270	0.56 max.	34	150	2100	0603

Continued on the following page. ↗

Continued from the preceding page.

Part Number	Inductance (nH)	Test Frequency (MHz)	Rated Current (mA)	DC Resistance (ohm)	Q (min.)	Test Frequency (MHz)	Self Resonance Frequency (min.) (MHz)	EIA
LQW18AN75NG00	75 ±2%	100	270	0.56 max.	34	150	2050	0603
LQW18AN75NJ00	75 ±5%	100	270	0.56 max.	34	150	2050	0603
LQW18AN82NG00	82 ±2%	100	250	0.60 max.	34	150	2000	0603
LQW18AN82NJ00	82 ±5%	100	250	0.60 max.	34	150	2000	0603
LQW18AN91NG00	91 ±2%	100	230	0.64 max.	34	150	1900	0603
LQW18AN91NJ00	91 ±5%	100	230	0.64 max.	34	150	1900	0603
LQW18ANR10G00	100 ±2%	100	220	0.68 max.	34	150	1800	0603
LQW18ANR10J00	100 ±5%	100	220	0.68 max.	34	150	1800	0603
LQW18ANR11G00	110 ±2%	100	200	1.2 max.	32	150	1350	0603
LQW18ANR11J00	110 ±5%	100	200	1.2 max.	32	150	1350	0603
LQW18ANR12G00	120 ±2%	100	180	1.3 max.	32	150	1600	0603
LQW18ANR12J00	120 ±5%	100	180	1.3 max.	32	150	1600	0603
LQW18ANR13G00	130 ±2%	100	170	1.4 max.	32	150	1450	0603
LQW18ANR13J00	130 ±5%	100	170	1.4 max.	32	150	1450	0603
LQW18ANR15G00	150 ±2%	100	160	1.5 max.	32	150	1400	0603
LQW18ANR15J00	150 ±5%	100	160	1.5 max.	32	150	1400	0603
LQW18ANR16G00	160 ±2%	100	150	2.1 max.	32	150	1350	0603
LQW18ANR16J00	160 ±5%	100	150	2.1 max.	32	150	1350	0603
LQW18ANR18G00	180 ±2%	100	140	2.2 max.	25	100	1300	0603
LQW18ANR18J00	180 ±5%	100	140	2.2 max.	25	100	1300	0603
LQW18ANR20G00	200 ±2%	100	120	2.4 max.	25	100	1250	0603
LQW18ANR20J00	200 ±5%	100	120	2.4 max.	25	100	1250	0603
LQW18ANR22G00	220 ±2%	100	120	2.5 max.	25	100	1200	0603
LQW18ANR22J00	220 ±5%	100	120	2.5 max.	25	100	1200	0603
LQW18ANR27G00	270 ±2%	100	110	3.4 max.	30	100	960	0603
LQW18ANR27J00	270 ±5%	100	110	3.4 max.	30	100	960	0603
LQW18ANR33G00	330 ±2%	100	85	5.5 max.	30	100	800	0603
LQW18ANR33J00	330 ±5%	100	85	5.5 max.	30	100	800	0603
LQW18ANR39G00	390 ±2%	100	80	6.2 max.	30	100	800	0603
LQW18ANR39J00	390 ±5%	100	80	6.2 max.	30	100	800	0603
LQW18ANR47G00	470 ±2%	100	75	7.0 max.	30	100	700	0603
LQW18ANR47J00	470 ±5%	100	75	7.0 max.	30	100	700	0603

Operating Temp. Range : -55°C to +125°C  
 Please use reflow soldering.

### ■ Q-Frequency Characteristics

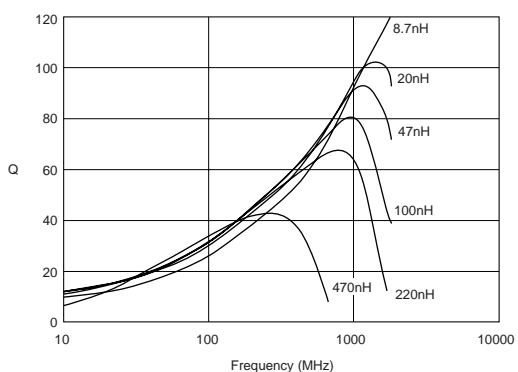

### ■ Inductance-Frequency Characteristics

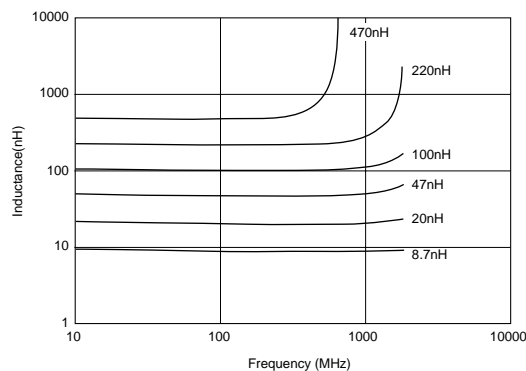

## LQW18A\_10 Series (High Q/Low DC Resistance Type)

Part Number	Inductance (nH)	Test Frequency (MHz)	Rated Current (mA)	DC Resistance (ohm)	Q (min.)	Test Frequency (MHz)	Self Resonance Frequency (min.) (MHz)	EIA
LQW18AN2N2D10	2.2 ±0.5nH	100	1400	0.018 max.	25	250	18000	0603
LQW18AN3N9C10	3.9 ±0.2nH	100	1000	0.032 max.	38	250	11000	0603
LQW18AN3N9D10	3.9 ±0.5nH	100	1000	0.032 max.	38	250	11000	0603
LQW18AN5N6D10	5.6 ±0.5nH	100	900	0.045 max.	38	250	10000	0603
LQW18AN6N8C10	6.8 ±0.2nH	100	900	0.045 max.	38	250	7000	0603
LQW18AN6N8D10	6.8 ±0.5nH	100	900	0.045 max.	38	250	7000	0603
LQW18AN8N2D10	8.2 ±0.5nH	100	800	0.058 max.	38	250	7000	0603
LQW18AN10NG10	10 ±2%	100	800	0.058 max.	38	250	5000	0603
LQW18AN10NJ10	10 ±5%	100	800	0.058 max.	38	250	5000	0603
LQW18AN12NG10	12 ±2%	100	750	0.071 max.	38	250	5000	0603
LQW18AN12NJ10	12 ±5%	100	750	0.071 max.	38	250	5000	0603
LQW18AN15NJ10	15 ±5%	100	700	0.085 max.	42	250	4500	0603
LQW18AN18NG10	18 ±2%	100	700	0.085 max.	42	250	3500	0603
LQW18AN18NJ10	18 ±5%	100	700	0.085 max.	42	250	3500	0603
LQW18AN22NG10	22 ±2%	100	640	0.099 max.	42	250	3200	0603
LQW18AN22NJ10	22 ±5%	100	640	0.099 max.	42	250	3200	0603
LQW18AN27NG10	27 ±2%	100	590	0.116 max.	42	250	2800	0603
LQW18AN27NJ10	27 ±5%	100	590	0.116 max.	42	250	2800	0603
LQW18AN33NJ10	33 ±5%	100	550	0.132 max.	42	250	2500	0603

Operating Temp. Range : -55°C to +125°C  
Please use reflow soldering.

### ■ Q-Frequency Characteristics

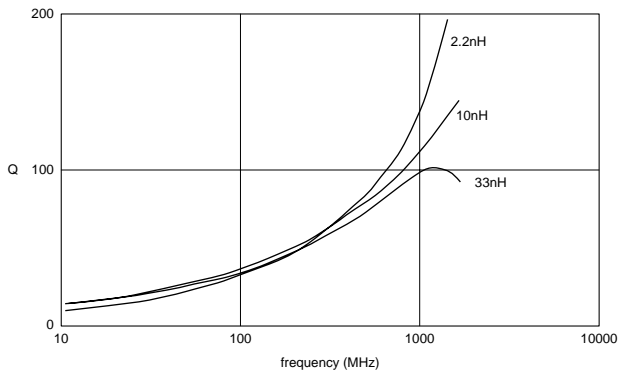

### ■ Inductance-Frequency Characteristics

